

3M Purification

3M™ HF27S

Water Filter Cartridge



The 3M™ Water Filtration Product Model HF27-S single cartridge water filtration assures consistent high quality water for commercial kitchen equipment and coffee machines by reducing the harmful effects of sediment and chlorine. Built-in scale inhibition reduces the ability of calcium and magnesium to precipitate on surfaces as hard scale.

HF27-S combines chlorine taste and odour reduction with sediment and scale reduction for higher turbidity water, and provides protection from harmful effects of chlorine corrosion and scale for up to 18,100 litres.

Features & Benefits

- Effectively reduces sediment and chlorine for equipment protection and clearer, great tasting coffee.
- Constructed from NSF Std 42 and FDA CFR 21 Materials to provide food safety assurances
- Built-in scale inhibitor reduces lime scale build-up on surfaces as tested by 3M Purification.
- Patented valve-in-head design simultaneously shuts off and vents water with 1/4 turn, allowing for simple and trouble-free cartridge change-outs.
- SQC™ – Sanitary Quick Change – encapsulated cartridge design allows for fast and easy change-outs with a 1/4 turn while minimizing the possibility of leakage and contamination.
- 3/8" FNPT horizontal inlet and outlet ports allow direct or easily adaptable connections to existing plumbing lines.
- Exhausted cartridges may be incinerated for environmentally conscious disposal.

Applications

- Coffee Machines
- Kitchen Equipment

Product Specifications

Model	Part Number	Micron Rating	Reduction Claims	Capacity	Service Flow Rate	Application
HF27S	70020044320	5	Sediment ¹ , Chlorine, Scale ¹ , Taste & Odour	18,170 litres	5.7 lpm	Taste, odour and scale reduction for coffee and vending

1. Tested and verified by manufacturer's laboratory.



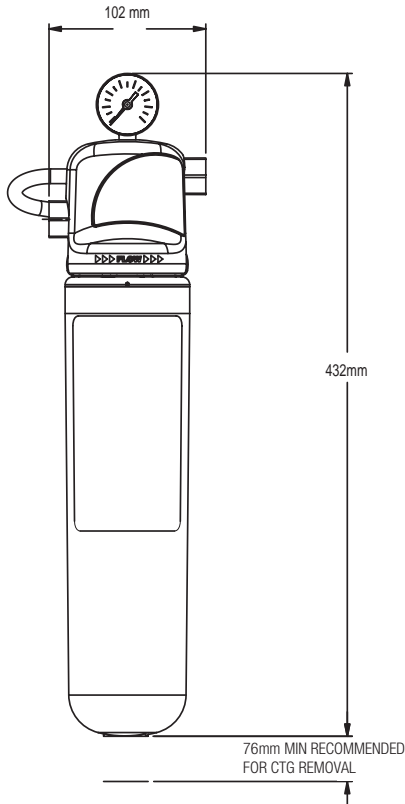

Physical Specifications

- Single Filter cartridges are o-ring seal type.
- Filter cartridge maximum operating pressure of 862 kPa (125 psi) and operating temperature of 37.8°C.
- Recommended service flow rate is up to 5.7 lpm.
- Filter cartridges incorporate carbon block filtration medium and scale inhibitor.
- Filter cartridges materials are NSF Standard 42 and/or FDA CFR-21 compliant.
- Cartridge body is constructed from high impact glass-filled polypropylene
- Cartridges are sanitary in design, requiring no contact with the filter media during cartridge change-out.
- Filter cartridges require no pre-activation.
- NSF Performance Data Sheet (PDS) is included.
- Shipping weight: 8.6 kg per case.
- Case quantity: 6.

IMPORTANT: Installation Tips

These installation tips are for informational purposes only and are not intended to be used as actual installation instructions.

CAUTION: To reduce the risk associated with property damage due to water leakage:

- Read and follow. Use Instructions before installation and use of this system.
- Installation and use. MUST comply with all state and local plumbing codes.
- Protect from freezing, remove filter cartridge when temperatures are expected to drop below 4.4°C (40°F).
- Do not install on hot water supply lines. The maximum operating water temperature of this filter system is 37.8°C (100°F).
- Do not install if water pressure exceeds 862 kPa (125 psi). As a requirement of the plumbing code, a pressure limiting valve and backflow prevention device must be installed. Contact a plumbing professional if you are uncertain how to check your water pressure.

WARNING: Do not use with water that is microbiologically unsafe or of unknown quality without adequate disinfection before or after the system. If system is not used for 2 days or more, flush 5-10 litres of water through before consuming water.

Important Notice

The information described in this literature is accurate to the best of our knowledge. A variety of factors, however, can affect the performance of the Product(s) in a particular application, some of which are uniquely within your knowledge and control. INFORMATION IS SUPPLIED UPON THE CONDITION THAT THE PERSONS RECEIVING THE SAME WILL MAKE THEIR OWN DETERMINATION AS TO ITS SUITABILITY FOR THEIR USE. IN NO EVENT WILL 3M PURIFICATION BE RESPONSIBLE FOR DAMAGES OF ANY NATURE WHATSOEVER RESULTING FROM THE USE OF OR RELIANCE UPON INFORMATION. It is your responsibility to determine if additional testing or information is required and if this product is fit for a particular purpose and suitable in your specific application.

Limitation of Liability

3M Purification Pty Limited will not be liable, to the extent permitted by law, for any loss or damage from the use of the Product(s), whether direct, indirect, special, or consequential, regardless of the legal theory asserted, included warranty, contract, negligence or strict liability.



3M Purification Pty Limited

140 Sunnyholt Road
Blacktown NSW 2148
Australia
Tel: 1300 367 362
Fax: 1800 671 599
www.3mpurification.com.au

3M New Zealand

94 Apollo Drive
Rosedale Auckland 0632
New Zealand
Tel: 0800 362 886
Fax: 0800 362 880
www.3M.com/nz

3M is a trademark of the 3M Company.
Please recycle. Printed in Australia.
© 3M 2014. All rights reserved.

AV011434329